

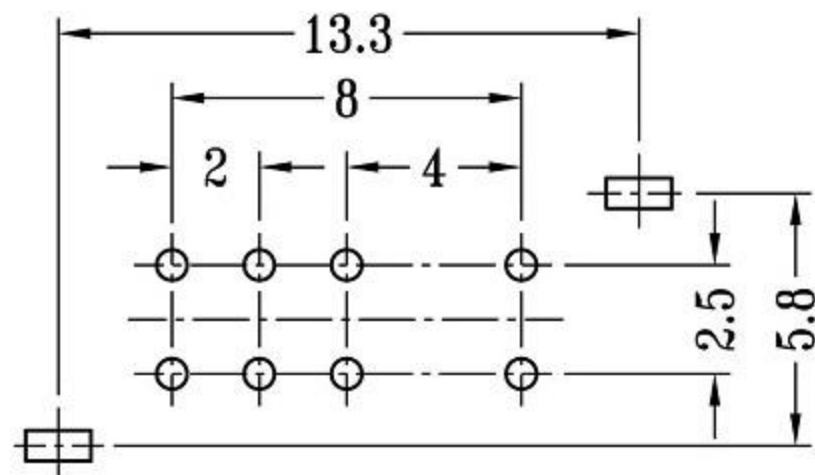

CAD FILE:

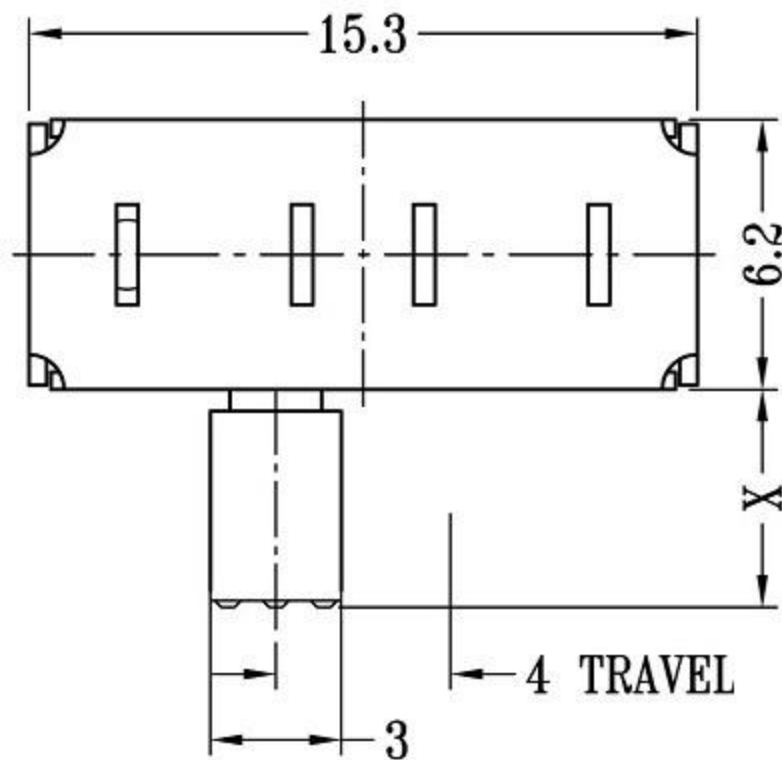

P.C.B LAYOUT
BOTTOM VIEW

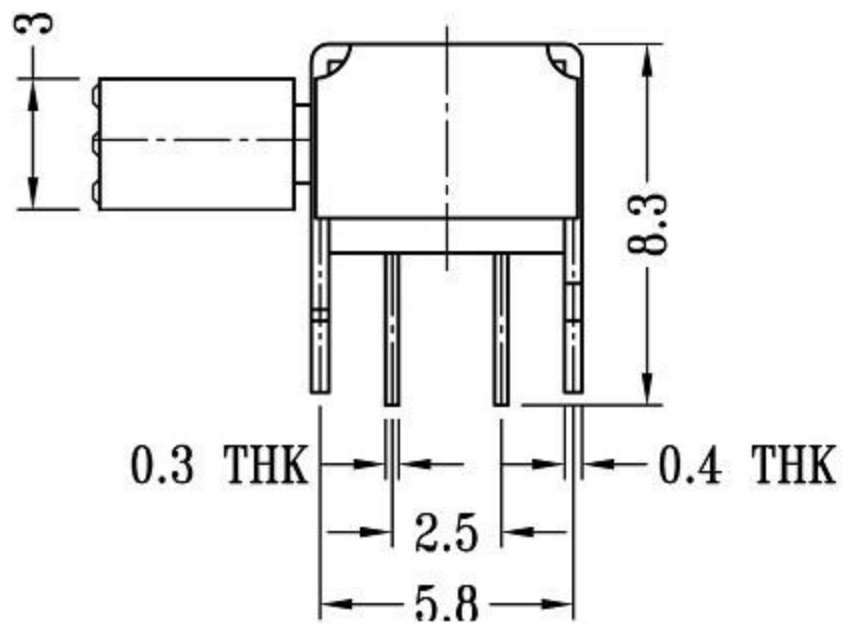
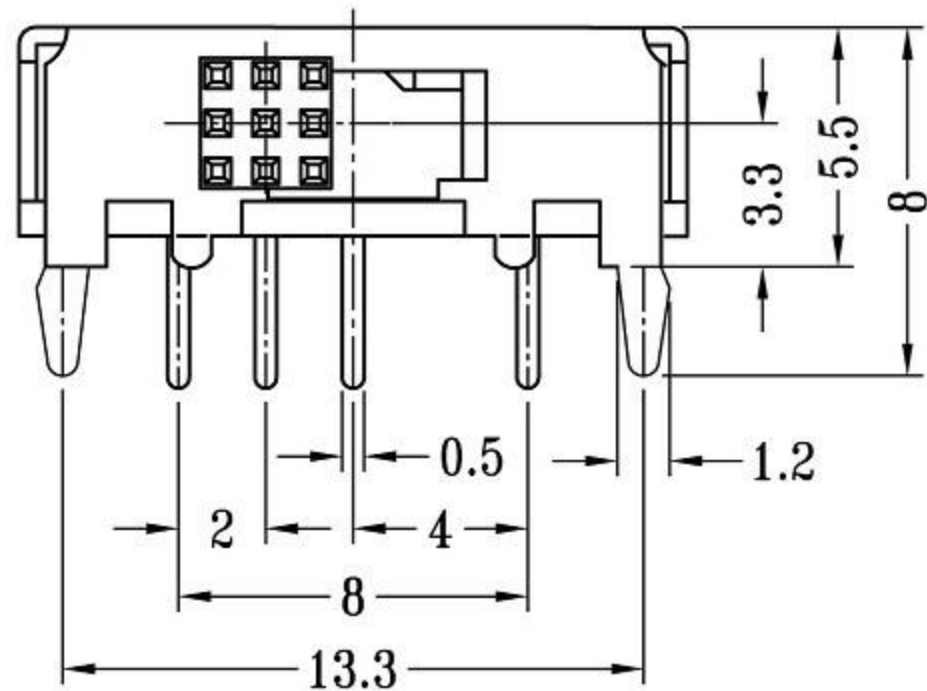
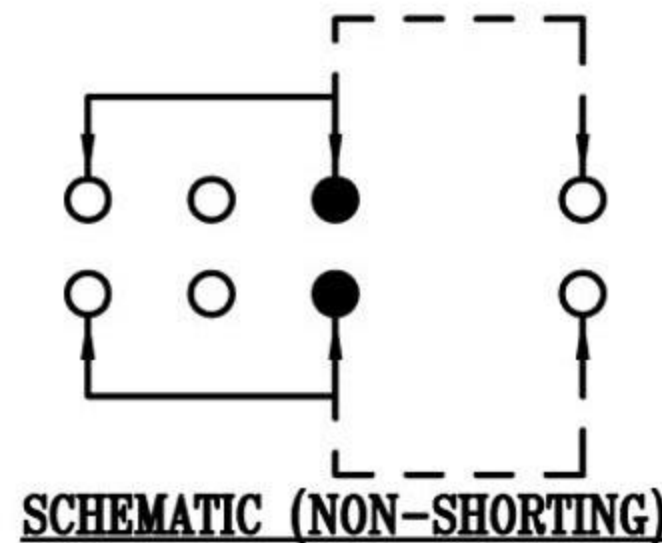

拨动开关侧拨技术参数:

1. 额定负荷: DC 30V 50V 0.3A 0.5A
2. 接触阻抗: $\leq 50m\Omega$
3. 绝缘阻抗: $\geq 100m\Omega$ DC500V
4. 耐焊温度: $250 \pm 5^\circ$ 5s
5. 使用寿命: 10,000 cycles
6. 使用温度: -25°C to 80°C
7. 使用湿度: $\leq 85\%$ RH
8. 操作力: 160gf 256gf 300gf 可定制
9. 手柄长度: 2mm-10mm 可定制

注: "*"表示关键尺寸(6个)

NO.	PARTS	MATERIALS	QTY	FINISH	TOLERANCE UNLESS SPECIFIED		DESCRIPTIONS OF REVISION		APPD
8					WITHIN	A	2012-12-25	初板	
7	STEEL BALL	STEEL	1	NATURAL	OVER	ISSUE	DATE		
6	SPRING	STEEL WIRE	1	NATURAL	TITLE: HORIZONTAL SLIDE SWITCH UNIT : mm				
5	CONTACT CLIP	PBS STRIP	2	Ag PLATED	MODEL: SCALE: 2:1				
4	TERMINAL	BRASS STRIP	10	Ag PLATED	DRWG NO.:				
3	BASE	PHENOLIC RESIN	1	BLACK	DWN 2012-12-25				
2	FRAME	STEEL STRIP	1	Ni PLATED	CHK'D				
1	KNOB	POM	1	BLACK	APPD 2012-12-25				
					东莞市高迪电子有限公司				